

LOC	DIST	REVISIONS					
HM	00	P	LTR	DESCRIPTION	DATE	DWN	APVD
		A		RLSD - NSD02-080	20NOV2002	LS	CD
		B		REV-EC 0B40-0187-04	25AUG2004	LH	CC
		C		REV ECO-06-019641	06OCT2006	LH	CC

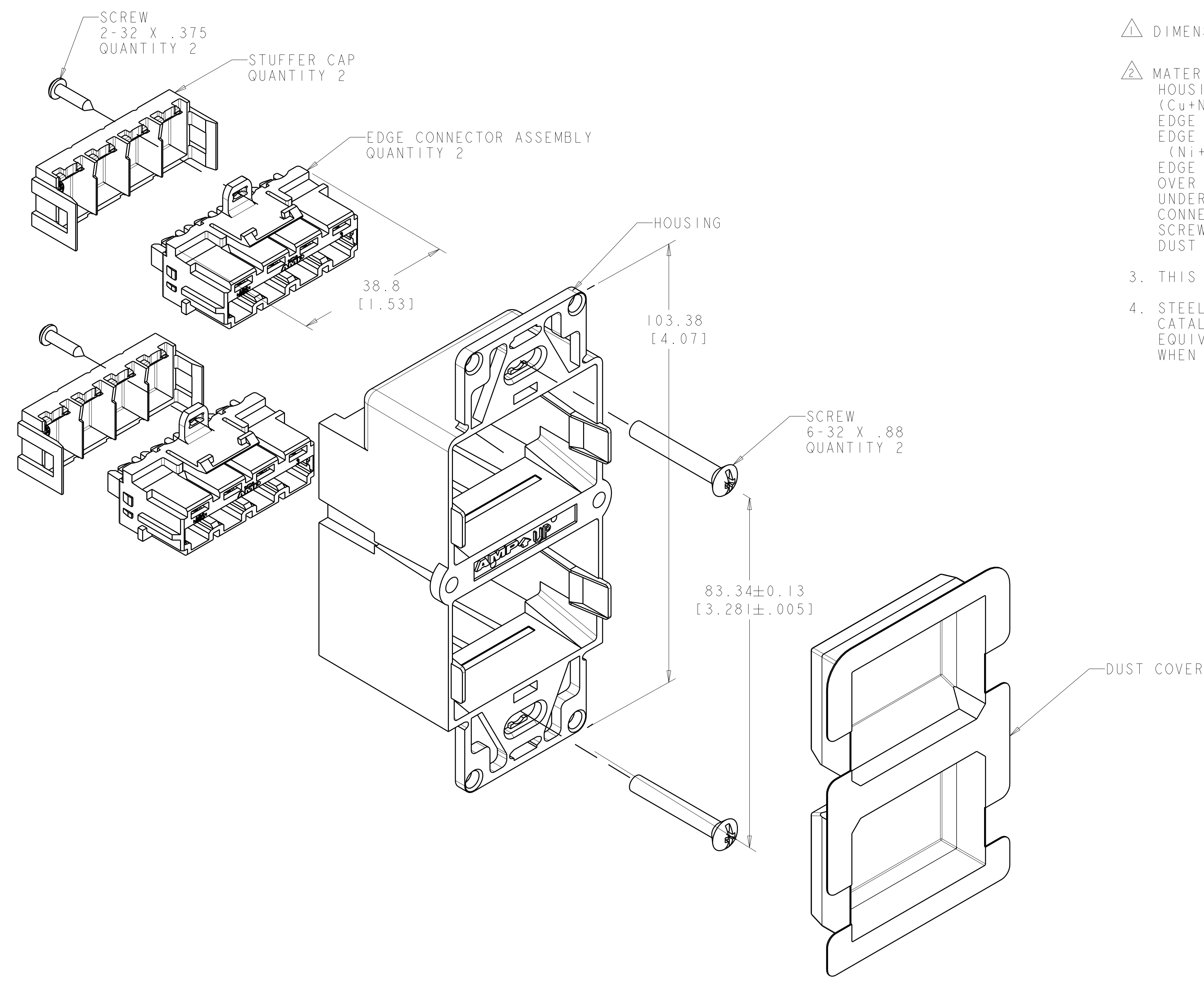

- ⚠ DIMENSIONS ARE MAXIMUM UNLESS OTHERWISE SHOWN.
- ⚠ MATERIAL:
 HOUSING - ABS MOLDING COMPOUND, BLACK, NICKEL PLATED (Cu+Ni).
 EDGE CONNECTOR HOUSING - ABS MOLDED COMPOUND, NICKEL PLATED (Cu+Ni).
 EDGE CONNECTOR COVERS - ABS MOLDING COMPOUND, NICKEL PLATED (Ni+Cu+Ni).
 EDGE CONNECTOR TERMINALS - PHOSPHOR BRONZE WITH GOLD PLATE OVER NICKEL PLATE IN CONTACT AREA AND TIN OVER NICKEL UNDERPLATE IN TERMINATION AREA.
 CONNECTION MODULES - POLYCARBONATE, GRAY
 SCREWS - ZINC PLATED CARBON STEEL.
 DUST COVER - 0.26[.010] THICK, CLEAR PVC.
3. THIS KIT SHIPPED ASSEMBLED EXCEPT FOR EDGE CONNECTOR COVERS.
4. STEEL CITY 4 INCH SQUARE DEVICE COVER FOR TWO DEVICES - CATALOG SERIES 52-C (OR TYCO ELECTRONICS APPROVED EQUIVALENT) IS RECOMMENDED FOR PROPER INSTALLATION WHEN DOUBLE GANG APPLICATION IS REQUIRED.

1479307-1
PART NO.

<small>THIS DRAWING IS UNPUBLISHED. RELEASED FOR PUBLICATION BY TYCO ELECTRONICS CORPORATION. ALL RIGHTS RESERVED.</small>		DWN L. SMITH 20NOV2002 CHK G. GARRETT 03JAN2003 APVD C. DOOLEY 03JAN2003	tyco Electronics Tyco Electronics Harrisburg, PA 17105-3608
DIMENSIONS: MM [INCHES]	TOLERANCES UNLESS OTHERWISE SPECIFIED: 9 PLC ±.1 1 PLC ±.1 2 PLC ±.1 3 PLC ±.1 4 PLC ±.1 ANGLES ±.1	NAME PRODUCT SPEC APPLICATION SPEC	INSTALL KIT, DUAL PORT, LOW PROFILE, ACO, CAT 6
MATERIAL:	FINISH:	WEIGHT: CUSTOMER DRAWING	SIZE: A1 CAGE CODE: 00779 DRAWING NO: C=1479307 RESTRICTED TO:
AMP 4805 REV 31MAR2000 Pro/ENGINEER DRAWING		SCALE: 2:1 SHEET: 1 OF 1 REV: C	